

# STAINLESS STEEL Y-TYPE STRAINER

SS304 PN16 F73Y16-50  
SS316 PN16 F73Y16-51



## FEATURES & SPECIFICATIONS

- Filter the particles and debris that may be carried by process fluid in the pipeline
- Bolted cover with drain plug
- Stainless steel perforated screen
- Face to face dimension to DIN 3202 F1
- Flange drilled to BS 4504 PN16 / EN 1092-2 PN16 / ANSI CLASS 150 (Specify on order)
- Applicable for Building Services, Air Conditioning, Fire Protection, Cold Water Plumbing, Hot Water System, Sewerage & Water Treatment, General Industries



## PRESSURE & TEMPERATURE RATINGS

Working Pressure	16bar
Shell Test Pressure (x1.5)	24bar
Seat Test Pressure (x1.1)	17.6bar
Working Temperature	-25°C ... 180°C
Suitable Media	Water, Oil & Gas

## MATERIAL SPECIFICATIONS

Part	Material	Specification
Body	Stainless Steel 304	EN 10088-3 1.4301
	Stainless Steel 316	EN 10088-3 1.4401
Screen	Stainless Steel 304	EN 10088-3 1.4301
	Stainless Steel 316	EN 10088-3 1.4401
Gasket	PTFE	
Gap	Stainless Steel 316	EN 10088-3 1.4401
Bonnet Bolt	Stainless Steel 304	EN 10088-3 1.4301
Stopper	Stainless Steel 316	EN 10088-3 1.4401

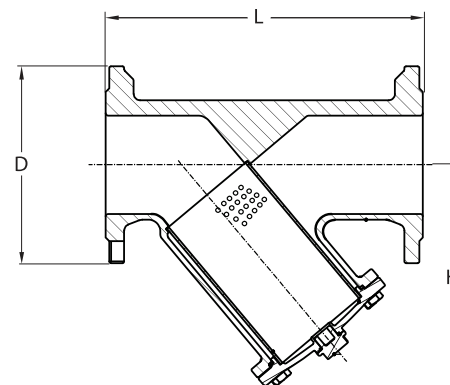

## SCREENS DATA

DN(mm)	Hole Dia. (mm)	Hole / inch <sup>2</sup>
15 ... 50	2	1
65 ... 200	3.5	2

## DIMENSIONS

DN (mm)	15	20	25	32	40	50	65	80	100	125	150	200
DN (inch)	½	¾	1	1¼	1½	2	2½	3	4	5	6	8
L	130	150	160	180	200	230	290	310	350	400	480	600
H	75	90	100	115	130	150	190	225	230	280	300	400
D	95	105	115	140	150	165	185	200	220	250	285	340

Fivalco® is Registered Trade Mark  
FIVALCO LIMITED  
info@fivalco.com | www.fivalco.com

Exclusive Distributor :  
**ENVALCO SDN. BHD.** (1039097-M)  
No. 30, Jalan PJU 3/46, Sunway Damansara Technology Park, 47810 Petaling Jaya, Selangor Darul Ehsan, Malaysia  
T: 603 - 7883 0018 | F: 603 - 7883 0012 | E: enquiry@envalco.com.my | W: www.envalco.com.my