

# HIGH RISER GATE VALVE RESILIENT SEATED OS&Y TYPE MECHANICAL JOINT ENDS

## 300PSI

## Fig No.: 3299-LI-300-MJ



### FEATURES & SPECIFICATIONS

- Rising stem, Outside Screw & Yoke (OS&Y)
- Stainless steel stem
- Valve conforms to AWWA C515 / BS5163
- Fusion bonded epoxy coated interior and exterior RAL3002
- Mechanical joint ends to AWWA C153 / A21.53
- Working pressure : 300psi
- Working temperature : -10°C ... 120°C



### MATERIALS LIST

Name	Material
Body	Ductile Iron ASTM A536 65-45-12
Wedge	Ductile Iron ASTM A536 65-45-12 + EPDM
Wedge Nut	Stainless Steel AISI 304
Stem	Stainless Steel AISI 304/420
Bonnet	Ductile Iron ASTM A536 65-45-12
Gasket	EPDM
Packing	Graphite
Stem Nut	Bronze ASTM B62
Handwheel	Ductile Iron ASTM A536 65-45-12

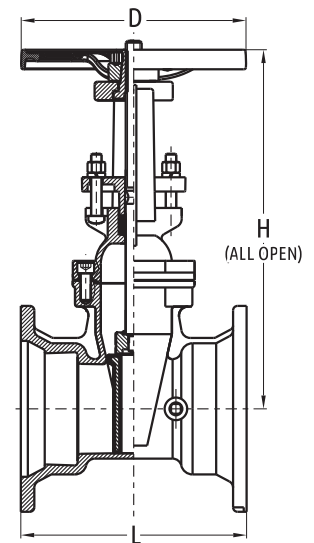

### DIMENSIONS (inch/mm)

Size	3"/80	4"/100	6"/150	8"/200	10"/250	12"/300
L	9.49/241	10.00/254	11.50/292	12.52/318	14.76/375	14.88/378
H	18.19/462	20.24/514	27.91/709	36.31/922	43.94/1116	51.18/1300
D	9.96/253	9.96/253	12.05/306	13.98/355	17.52/445	17.52/445

### NET WEIGHT (kg) & CRATE QTY (pcs)

Size	3"/80	4"/100	6"/150	8"/200	10"/250	12"/300
N.W.	22.13	27.16	46.90	72.00	111.00	167.00
Crate Qty	16	16	9	6	4	2

Fivalco® is Registered Trade Mark  
**FIVALCO LIMITED**  
 info@fivalco.com | www.fivalco.com

Exclusive Distributor:  
**ENVALCO SDN. BHD.** (1039097-M)  
 No. 30, Jalan PJU 3/46, Sunway Damansara Technology Park, 47810 Petaling Jaya, Selangor Darul Ehsan, Malaysia  
 T: 603 - 7883 0018 | F: 603 - 7883 0012 | E: enquiry@envalco.com.my | W: www.envalco.com.my

Fivalco reserves the right to alter the information in this document without prior notice. Fivalco shall not be liable for technical errors or omissions contained herein.