

INDICATOR POST

Fig No.: IPO888



MATERIALS LIST

No.	QTY.	Name	Material
1	1	Locking Wrench	ASTM A126B
2	1	Operating Nut	ASTM B62
3	2	Hex Nut Screw	ASTM A105
4	2	Hex Nut	ASTM A105
5	1	Snap Ring	AISI 066
6	1	Target Carrier Nut	ASTM B62
7	4	Target	ASTM B108
8	4	Hex Cap Nut	ASTM A105
9	2	Window Glass	LEXAN-UM
10	2	Window Glass Gasket	PTFE
11	4	Hex Cap Screw	ASTM A105
12	4	Hex Nut	ASTM A105
13	1	Body	ASTM A536
14	6	Hex Cap Screw	ASTM A105
15	6	Hex Nut Screw	ASTM A105
16	1	Hex Nut	ASTM A126B
17	4	Base Flange	ASTM A105
18	4	Hex Nut	ASTM A105
19	1	Crane Coupling	ASTM A536
20	1	Cotter Pin	AISI 304
21	1	Stand Pipe	ASTM A53
22	1	Stem	AISI 1045
23	1	Plug	AISI 304
24	1	Cover	ASTM A126B
25	1	Cross Recessed Countersunk Head Screw	AISI 304
26	1	Locking Nose	ASTM 307 B

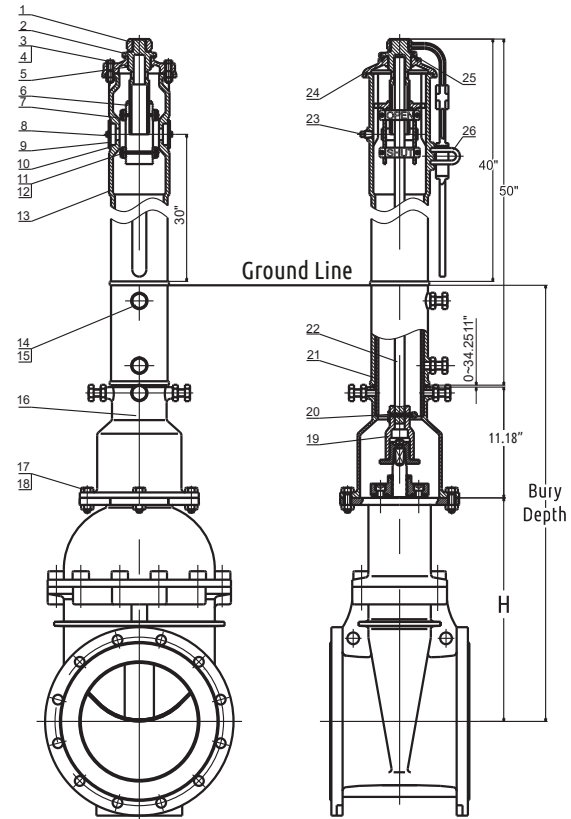

BURY DEPTH

Size	Min. Bury Depth (mm/inch)	Max. Bury Depth (mm/inch)	H	
			mm	inch
2"	623 / 24.53"	1493 / 58.78"	173	6.81"
2½"	623 / 24.53"	1493 / 58.78"	173	6.81"
3"	643 / 25.32"	1513 / 59.57"	193	7.60"
4"	667 / 26.26"	1537 / 60.51"	217	8.54"
5"	728 / 28.66"	1598 / 62.91"	278	10.94"
6"	762 / 30.00"	1632 / 64.25"	312	12.28"
8"	847 / 33.35"	1717 / 67.60"	397	15.63"
10"	942 / 37.09"	1812 / 71.34"	492	19.37"
12"	1028 / 40.47"	1898 / 74.72"	578	22.76"

Note : Indicator post of 2" - 3" only suitable for Fivalco Fig. 3288-LI series gate valves.

FIELD ADJUSTMENT

1. Remove the top section from the top of the Indicator Post assembly.
2. Cut the required length off the bottom of the Standpipe for the Gound Line to match up with Standpipe Gound Line mark.
3. Set the "OPEN" and "SHUT" targets for the appropriate valve size.
4. Reattach the Top Section to the top of the Indicator Post assembly.

Fivalco® is Registered Trade Mark
FIVALCO LIMITED
 info@fivalco.com | www.fivalco.com

Exclusive Distributor :
ENVALCO SDN. BHD. (1039097-M)
 No. 30, Jalan PJU 3/46, Sunway Damansara Technology Park, 47810 Petaling Jaya, Selangor Darul Ehsan, Malaysia
 T: 603 - 7883 0018 | F: 603 - 7883 0012 | E: enquiry@envalco.com.my | W: www.envalco.com.my