



# Variable Orifice Double Regulating Valve

Fig. F63V16 (PN16) / F63V25 (PN25)

# VARIABLE ORIFICE DOUBLE REGULATING VALVE

PN16 F63V16  
PN25 F63V25

## FEATURES & SPECIFICATIONS

- Variable orifice single unit Y-pattern globe valves
- Fitted with a pair of measuring plugs
- Microset handwheel and presetting scale is readable from all directions
- Regulating and isolating functions
- Setting can be locked with allen key
- Flange drilled to BS 4504 PN16 / EN 1092-2 PN16 / BS 4504 PN25 / EN 1092-2 PN25 / ANSI Class 150 (Specify on order)
- Comply with BS 7350
- Applicable for hydronic balancing of heating and cooling systems



## PRESSURE & TEMPERATURE RATINGS

Working Pressure	16bar	25bar
Shell Test Pressure (x1.5)	24bar	37.5bar
Seat Test Pressure (x1.1)	17.6bar	27.5bar
Working Temperature	-10°C ... 120°C	
Suitable Media	Water	

## MATERIAL SPECIFICATIONS

Part	Material	Specification
Body	Ductile Iron	EN-JS 1040
Bonnet	Ductile Iron	EN-JS 1040
Stem	Stainless Steel 410 (DN65 ... DN300)	EN 10088-3 1.4006
	Stainless Steel 431 (DN350 ... DN600)	EN 10088-3 1.4057
Balancing Cone	Ductile Iron	EN-JS 1040
Disc	EPDM coated DI	EN-JS 1040
Gland	Brass (DN65 ... DN150)	EN 12165 CW617N
	Ductile Iron (DN200 ... DN600)	EN-JS 1040
Gland Nut	Brass	EN 12165 CW617N
Orifice Insert	DZR Brass	EN 12165 CW602N
Measuring Plug	DZR Brass	EN 12165 CW602N
Handwheel	Ductile Iron	EN-JS 1040
Packing	Graphite	Non-Asbestos

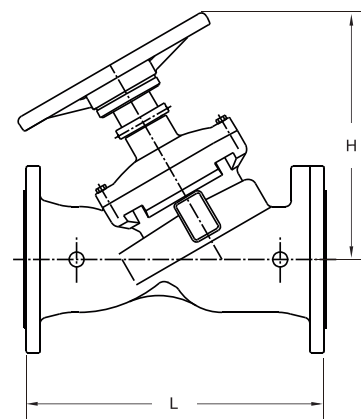

## DIMENSIONS & FLOW COEFFICIENT

DN (mm) DN (inch)	65 2½	80 3	100 4	125 5	150 6	200 8	250 10	300 12	350 14	400 16	450 18	500 20	600 24
L	290	310	350	400	480	600	730	850	980	1100	1200	1250	1450
H	263	268	300	328	340	525	572	686	681	965	972	1065	1180
D	200	200	240	290	290	350	420	420	420	640	640	640	640
Flow Kv	83.8	119.5	178.7	272.7	380.0	608.0	1292.0	1791.0	1824.0	2098.0	2372.0	2640.0	4940.0
Head K	3.78	5.24	9.53	6.98	5.35	6.26	5.57	6.43	11.40	12.40	13.10	13.50	13.90

(mm)

# VARIABLE ORIFICE DOUBLE REGULATING VALVE

PN16 F63V16  
PN25 F63V25



Size 2½" (DN 65)  
Handwheel Setting (Number of turns)

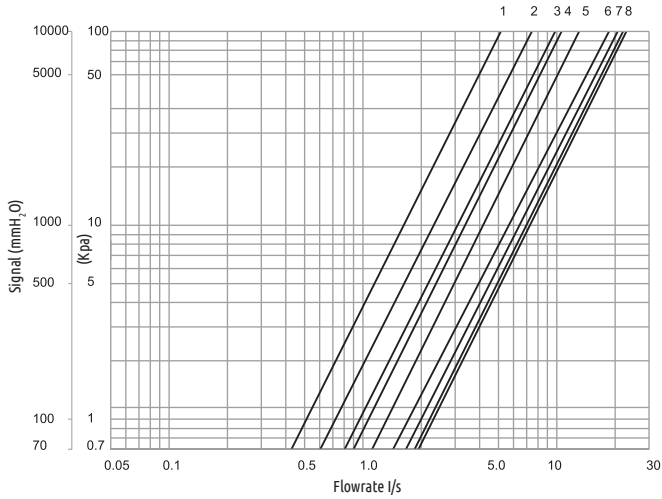

Handwheel Position	1	2	3	4	5
Kv Value	18.6	26.8	35.4	38.7	49.4
Handwheel Position	6	7	8	Fully Open	
Kv Value	65.5	74.6	80.2	83.8	

Size 3" (DN 80)  
Handwheel Setting (Number of turns)

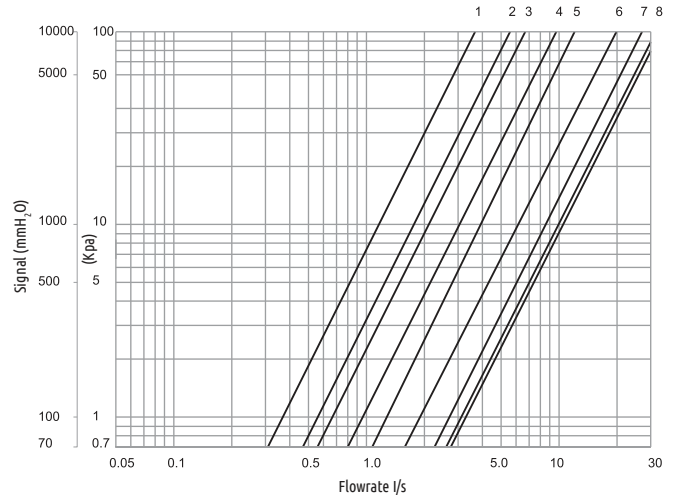

Handwheel Position	1	2	3	4	5
Kv Value	13.3	20.0	24.1	34.9	45.9
Handwheel Position	6	7	8	Fully Open	
Kv Value	71.6	98.8	113.7	119.5	

Size 4" (DN 100)  
Handwheel Setting (Number of turns)

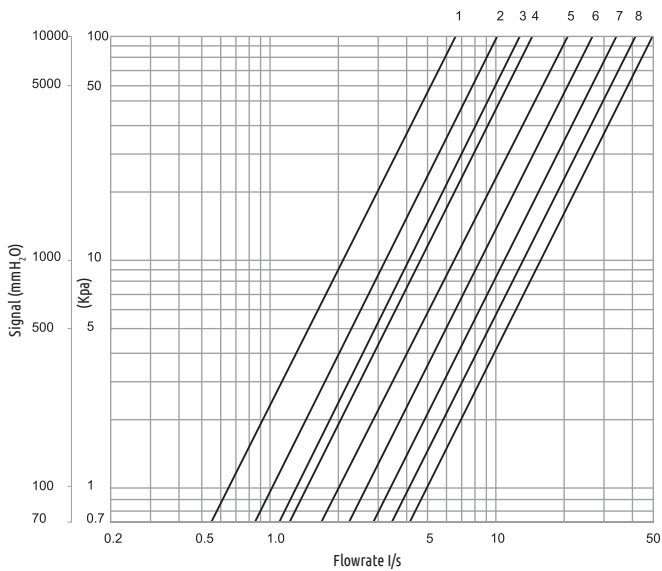

Handwheel Position	1	2	3	4	5
Kv Value	23.6	36.6	48.5	55.2	75.2
Handwheel Position	6	7	8	Fully Open	
Kv Value	97.9	123.9	149.4	178.7	

Size 5" (DN 125)  
Handwheel Setting (Number of turns)

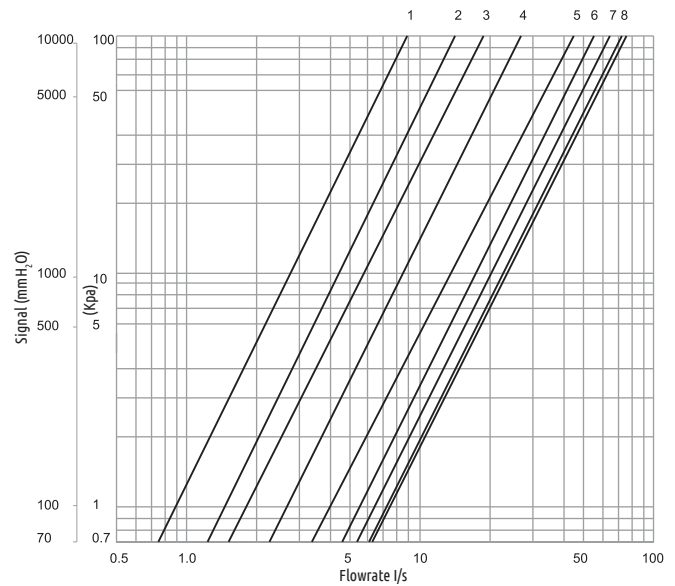

Handwheel Position	1	2	3	4	5
Kv Value	32.2	55.6	68.8	98.0	145.7
Handwheel Position	6	7	8	Fully Open	
Kv Value	199.1	231.7	260.5	272.7	

# VARIABLE ORIFICE DOUBLE REGULATING VALVE

PN16 F63V16  
PN25 F63V25



Size 6" (DN 150)  
Handwheel Setting (Number of turns)

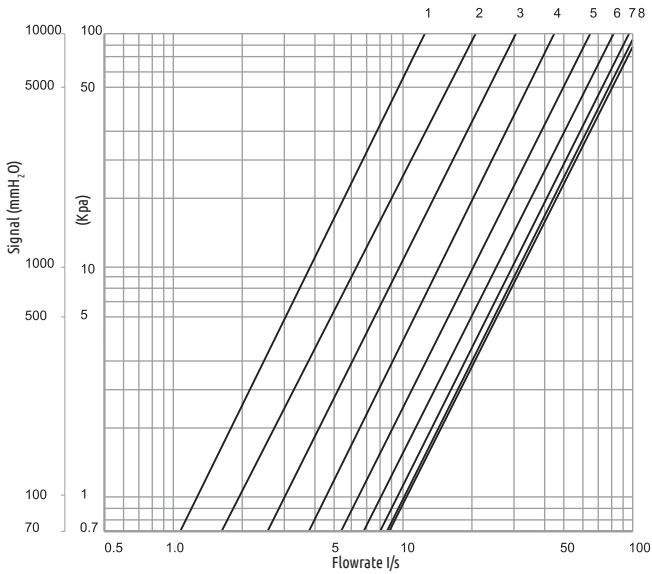

Handwheel Position	1	2	3	4	5
Kv Value	48	75	110	162	233

Handwheel Position	6	7	8	Fully Open
Kv Value	294	346	371	380

Size 8" (DN 200)  
Handwheel Setting (Number of turns)

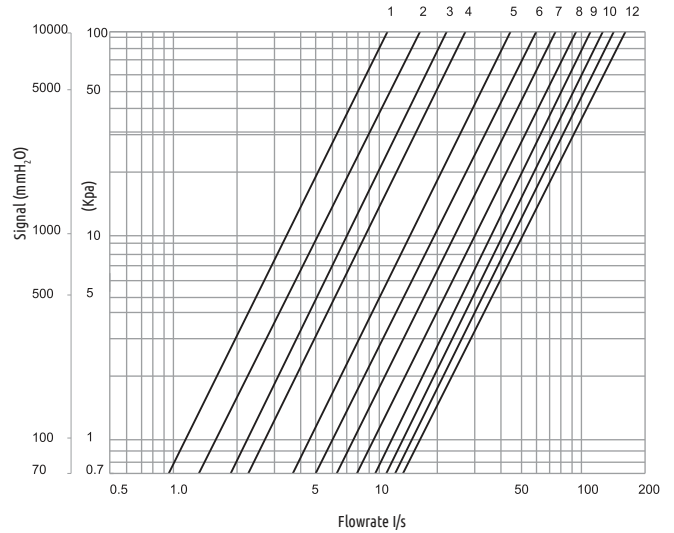

Handwheel Position	1	2	3	4	5	6
Kv Value	41	61	81	99	161	215

Handwheel Position	7	8	9	10	11	Fully Open
Kv Value	271	339	412	482	546	608

Size 10" (DN 250)  
Handwheel Setting (Number of turns)

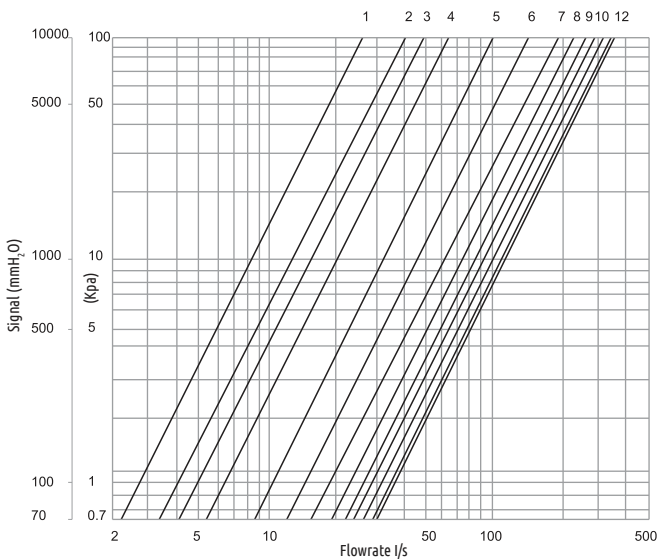

Handwheel Position	1	2	3	4	5	6
Kv Value	97	146	177	232	368	543

Handwheel Position	7	8	9	10	11	12	Fully Open
Kv Value	695	832	960	1045	1151	1249	1292

Size 12" (DN 300)  
Handwheel Setting (Number of turns)

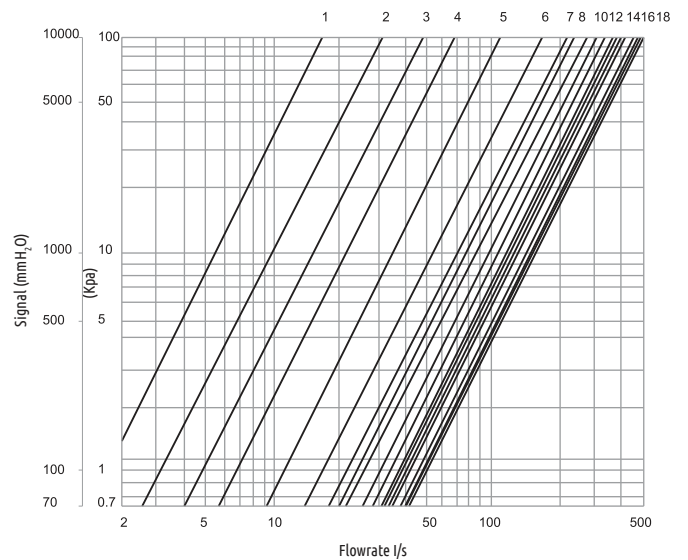

Handwheel Position	1	2	3	4	5	6	7	8	9	10
Kv Value	63	113	174	245	397	628	792	873	1002	1112

Handwheel Position	11	12	13	14	15	16	17	18	Fully Open
Kv Value	1223	1331	1383	1444	1505	1639	1707	1730	1791

# VARIABLE ORIFICE DOUBLE REGULATING VALVE

PN16 F63V16  
PN25 F63V25



Size 14" (DN 350)  
Handwheel Setting (Number of turns)

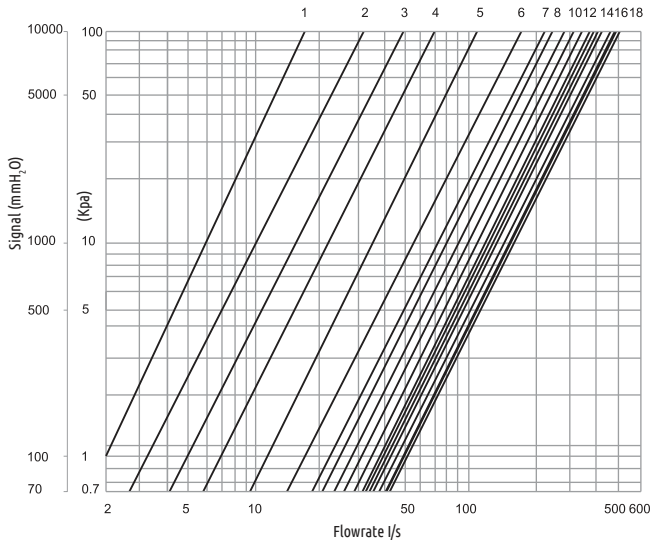

Handwheel Position	1	2	3	4	5	6	7	8	9	10
Kv Value	64	115	177	250	404	639	807	889	1020	1132
Handwheel Position	11	12	13	14	15	16	17	18	Fully Open	
Kv Value	1246	1355	1409	1470	1533	1669	1739	1762	1824	

Size 16" (DN 400)  
Handwheel Setting (Number of turns)

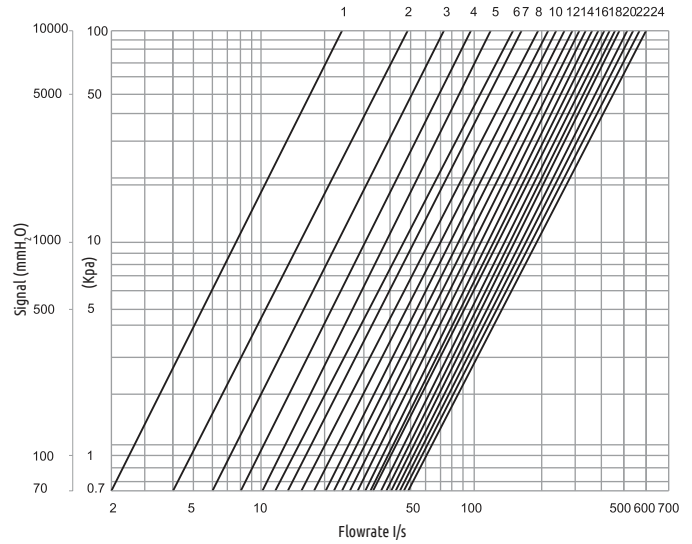

Handwheel Position	1	2	3	4	5	6	7	8
Kv Value	87	175	262	350	437	525	612	699
Handwheel Position	9	10	11	12	13	14	15	16
Kv Value	787	874	962	1049	1136	1224	1311	1399
Handwheel Position	17	18	19	20	21	22	23	24
Kv Value	1486	1574	1661	1748	1836	1923	2011	2098

Size 18" (DN 450)  
Handwheel Setting (Number of turns)

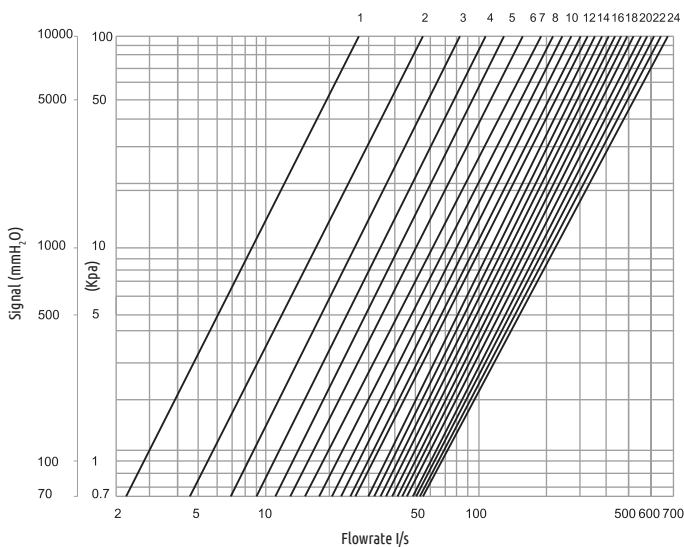

Handwheel Position	1	2	3	4	5	6	7	8
Kv Value	99	198	296	395	494	593	692	791
Handwheel Position	9	10	11	12	13	14	15	16
Kv Value	889	988	1087	1186	1285	1384	1482	1581
Handwheel Position	17	18	19	20	21	22	23	24
Kv Value	1680	1779	1878	1977	2075	2174	2273	2372

Size 20" (DN 500)  
Handwheel Setting (Number of turns)

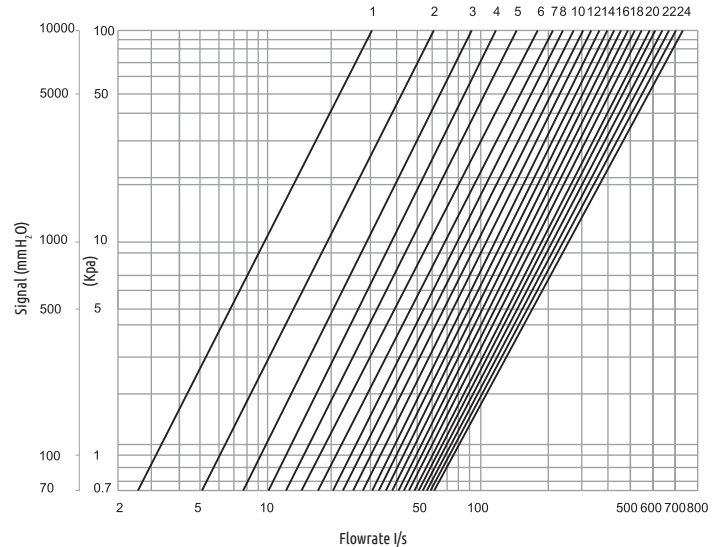

Handwheel Position	1	2	3	4	5	6	7	8
Kv Value	110	220	330	440	550	660	770	880
Handwheel Position	9	10	11	12	13	14	15	16
Kv Value	990	1100	1210	1320	1430	1540	1650	1760
Handwheel Position	17	18	19	20	21	22	23	24
Kv Value	1870	1980	2090	2200	2310	2420	2530	2640

# VARIABLE ORIFICE DOUBLE REGULATING VALVE

PN16 F63V16  
 PN25 F63V25

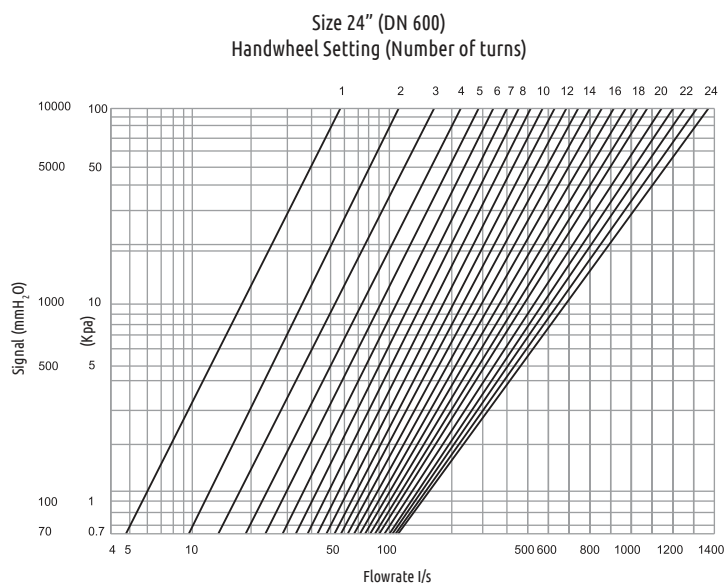

Handwheel Position	1	2	3	4	5	6	7	8
Kv Value	206	412	617	823	1029	1235	1441	1647
Handwheel Position	9	10	11	12	13	14	15	16
Kv Value	1852	2058	2264	2470	2676	2882	3087	3293
Handwheel Position	17	18	19	20	21	22	23	24
Kv Value	3499	3705	3911	4117	4322	4528	4734	4940

## INSTALLATION & OPERATION GUIDE

Install the Double Regulating Valve in the pipe line by ensuring the arrow marking on the valve is same direction as piping flow.

To achieve flow measurement accuracy, it is essential that the piping on the inlet and outlet of the valve is straight and has a minimum length equivalent to 5 Diameters (5D) inlet and 2 Diameters (2D) outlet as shown. If the valve is install at the discharge side of a pump set, it is essential that the straight pipe length between pump outlet and valve has a minimum length of 10 Diameters (10D).

Gaskets must be used and assembled between valve and flanges. This will ensure the installation is concentric with pipe line and better accuracy is obtained.

Design flow is achieved by pre-setting valve's opening position, which could be read from scales at the handwheel. Contact your local distributor for information on electronic commissioning meter.

To lock the pre-setting of the valve, push the limitation ring at the scales at the bottom of the handwheel, tighten the screw using the hexagon wrench.

Valve must not be lifted by holding the handwheel.

